

Desktop Currency Sorter USF-100

Specifications

Product Name:	Currency Sorter
Counting Speed:	Approx. 650 notes/min.
Hopper Capacity:	Approx. 500 notes
Stacker Capacity:	Approx. 200 notes x 2
Reject Stacker Capacity:	Switchable 50/100 notes
Power Supply:	100 — 240 V ± 10 %: 1.2 — 0.8 A, 50/60 Hz
Dimensions:	500 mm (W) x 430 mm (D) x 450 mm (H)
Weight:	Approx. 42 kg
External Connection (option):	RS-232C x 2 for PC and Printer Interface (CITIZEN iDP-3550, STAR MICRONICS TSP-600 series) RS-232C x 1 for External Display



Desktop Currency Sorter

USF-100

Dimensions & Required Installation Space

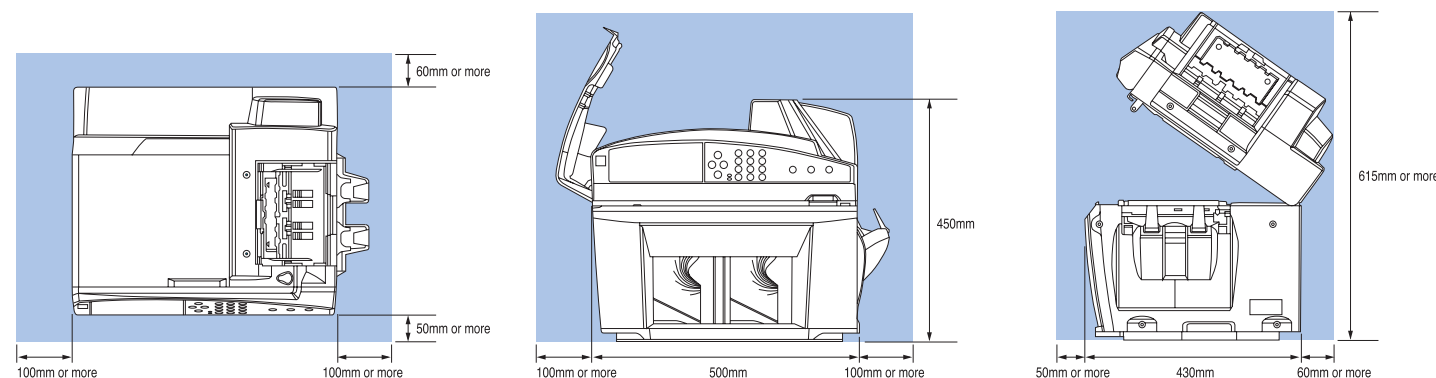

Product Line Up



USF-100



LW-500



LW-600

* Specifications are subject to change without notice.
* Please carefully read the instruction manual to ensure correct equipment usage.
* Copyright © 2008 by GLORY LTD. All rights reserved.



We Secure the Future

Manufactured by
GLORY LTD.
<http://www.glory.co.jp/en>
Akihabara UDX, 4-14-1 Soto-Kanda, Chiyoda-Ku, Tokyo 101-8977, Japan
Tel: +81-3-5207-3110 / Fax: +81-3-5207-3030

U.S.A.
GLORY (U.S.A.) Inc.
Corporate Headquarters
10 York Avenue, West Caldwell, NJ 07006
Tel: +1-800-999-4510 / Fax: +1-973-228-7114

EUROPE
GLORY Europe GmbH
Königsberger Str. 1, 60487 Frankfurt am Main, Germany
Tel: +49-69-7953 880 / Fax: +49-69-7953 8870

SOUTHEAST ASIA & OCEANIA
GLORY Money Handling Machines Pte. Ltd.
9 Temasek Boulevard #44-01, Suntec Tower 2, Singapore 038989
Tel: +65-6837-2813 / Fax: +65-6837-2803

HONG KONG
GLORY Cash Handling Systems (China) Ltd.
Rm. 611, Lu Plaza, 2 Wing Yip St., Kwun Tong, Kowloon, Hong Kong
Tel: +852-2628-1800 / Fax: +852-2628-1802

CHINA
GLORY International Trading (Shanghai) Co., Ltd.
Room 3011, Hua Ting Guest House, 2525 Zhong Shan Road (W),
Shanghai 200030, P. R. of China
Tel +86-21-6439-7921, -4185 / Fax +86-21-6439-4010

Distributed by:

**Ideal for sorting mixed banknotes
by fitness, denomination, and orientation,
this compact sorter achieves high productivity,
accuracy, and reliable counterfeit detection.**



GLORY's New Currency Sorter Improves Cash Management Efficiency by Recycling the Banknotes in the Branch and Reduces the Workload While Achieving High Accuracy and Efficient Productivity.

Recently, the demand has grown for more efficient cash management at branches, resulting in the installation of a banknote sorter at each branch. The Currency Sorter USF-100 was developed to meet this demand for banknote recycling. The USF-100 is equipped with both the high performance and easy operability of its higher-end counterparts, such as the UW-500 and UW-600*.

* Please refer to backside Product Line-up.



Double-LCD Display with Illustrated Operator Guidance

For ease of use and operation

The display section features two side-by-side LCDs, one for displaying data and messages and the other for use as an illustrated system guide. Wide display screens substantially improve visibility.



Counting Result and Status
The display section shows the total amount and number of banknotes by denomination and the total processing data. In the event of an error, the display section indicates a description of how to reset the system.



Example of error reset procedure display
The display shows the status of the system. If an error occurs, the display section describes the status and location of the error.

Large-Capacity Hopper with an Assisted Feeding Mechanism

For a lower incidence of feeding issues of due to poor quality banknotes

The large-capacity hopper holds 500 banknotes. Thanks to the Assisted Feeding Mechanism the hopper reliably feeds one note at a time to prevent jamming or high rejects due to double feeding. The open-type hopper lets you keep an eye on the banknote feeding process so you can add more notes in continuous large-volume deposits.



Equipped with two stackers and one reject stacker, the USF-100 accurately and quickly sorts mixed banknotes by fitness, oldness, denomination, and orientation.

Next Generation Sensors with

Superb Counterfeit Detection

Banknote handling machines must deliver both high efficiency and a combination of speed and accuracy. GLORY's USF-100 offers Next Generation Sensors for Fitness Sorting and Superb Counterfeit Detection while processing at a remarkably high rate of speed of 650 notes per minute.

The ability of the USF-100 to accurately assess fitness and detect counterfeit banknotes has passed the strict framework standards of the European Central Bank (ECB).

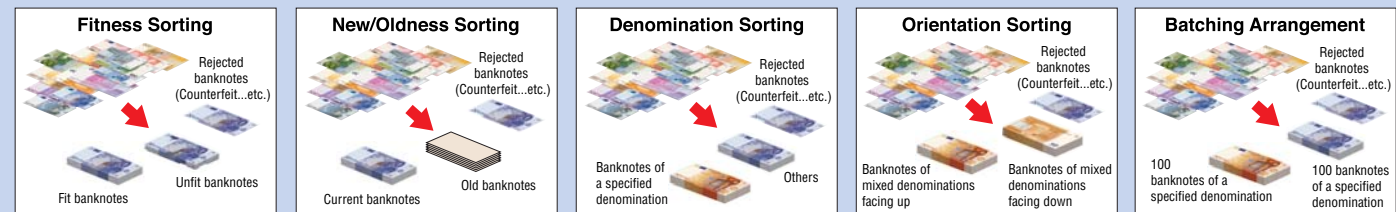
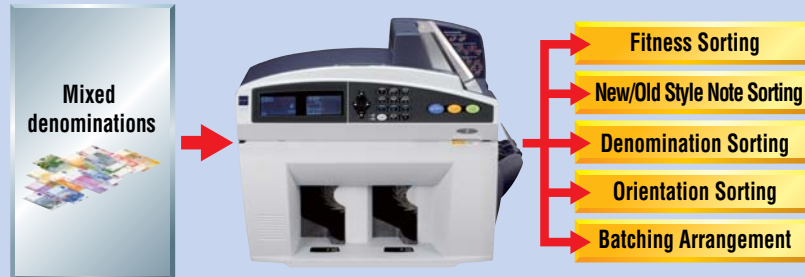

Desktop Currency Sorter USF-100

By sorting cash at the branch, you can reduce the amount of cash to be transported.

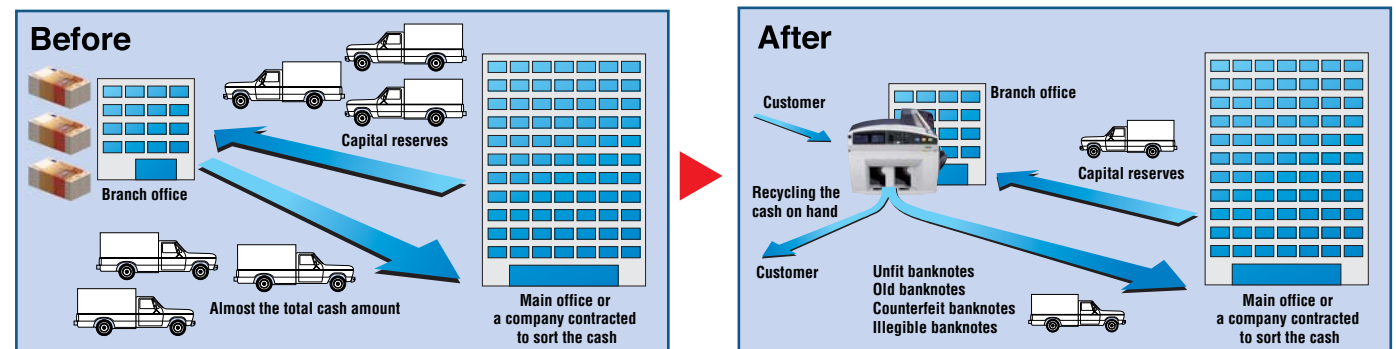

When cash sorting is outsourced:

- It is difficult to reduce the amount of capital reserves for use in the branch.
- It is difficult to reduce the number of cash transport cycles between main and branch offices.

By using USF-100 to increase the ratio of the cash sorted in the branch:

- Fit and current banknotes can be recycled as branch reserves.
- Unfit or old banknotes and surplus cash are sent to the main office or to a company contracted to handle it.
- Cash management efficiency is improved and the amount of capital reserves on hand can be reduced.
- By automating the cash sorting task with the USF-100, the branch's workload can also be reduced.

2-Teller Operation

The time for sorting can be further reduced

When the USER button on the control panel is pressed, the A/B indicator lights to indicate the current user. The processed data is stored in memory for users A and B, so the data can be easily compiled and understood.

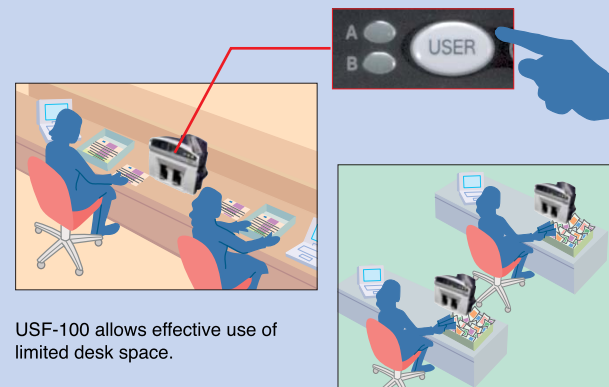

USF-100 allows effective use of limited desk space.

Easier Maintenance

Quick JAM Recovery reduces processing interruptions

The system features a completely opening top that allows easy maintenance of the banknote transport section. Should banknotes jam or foreign object in the counting or transport section, the wide-opening upper section of the main unit makes it easy to find and remove the jammed notes or foreign object. A dust tray is also provided for easy removal of accumulated dust.

